

SERIES 150 HANDRAIL & BRACKET

DRAWING TITLE:
 TOP VIEW, ELEVATION
 BRACKET SECTION AND DETAIL

DRAWN BY: JCHU
 DATE-MDY: 3-14-2012

DRAWING #:

150.1

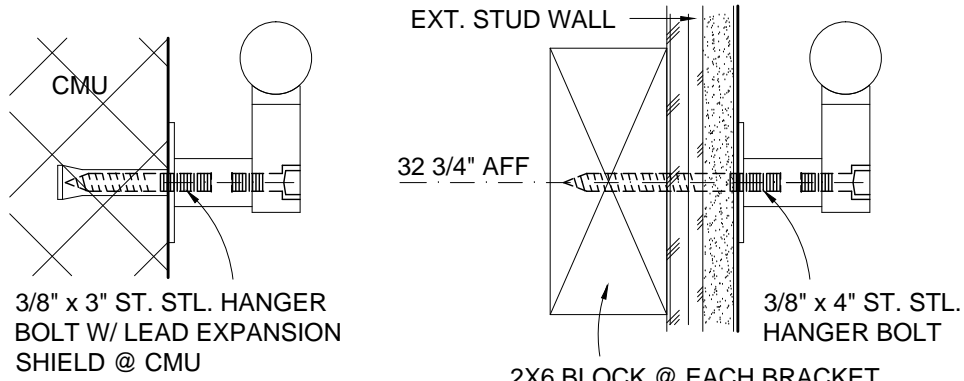

EXT. STUD WALL
 32 3/4" AFF
 3/8" x 4" ST. STL. HANGER BOLT
 2X6 BLOCK @ EACH BRACKET
 32 3/4" O.C. RECOMMEND CONT
 BLOCKING FOLLOW NOSE OF STAIR
 AND LANDING

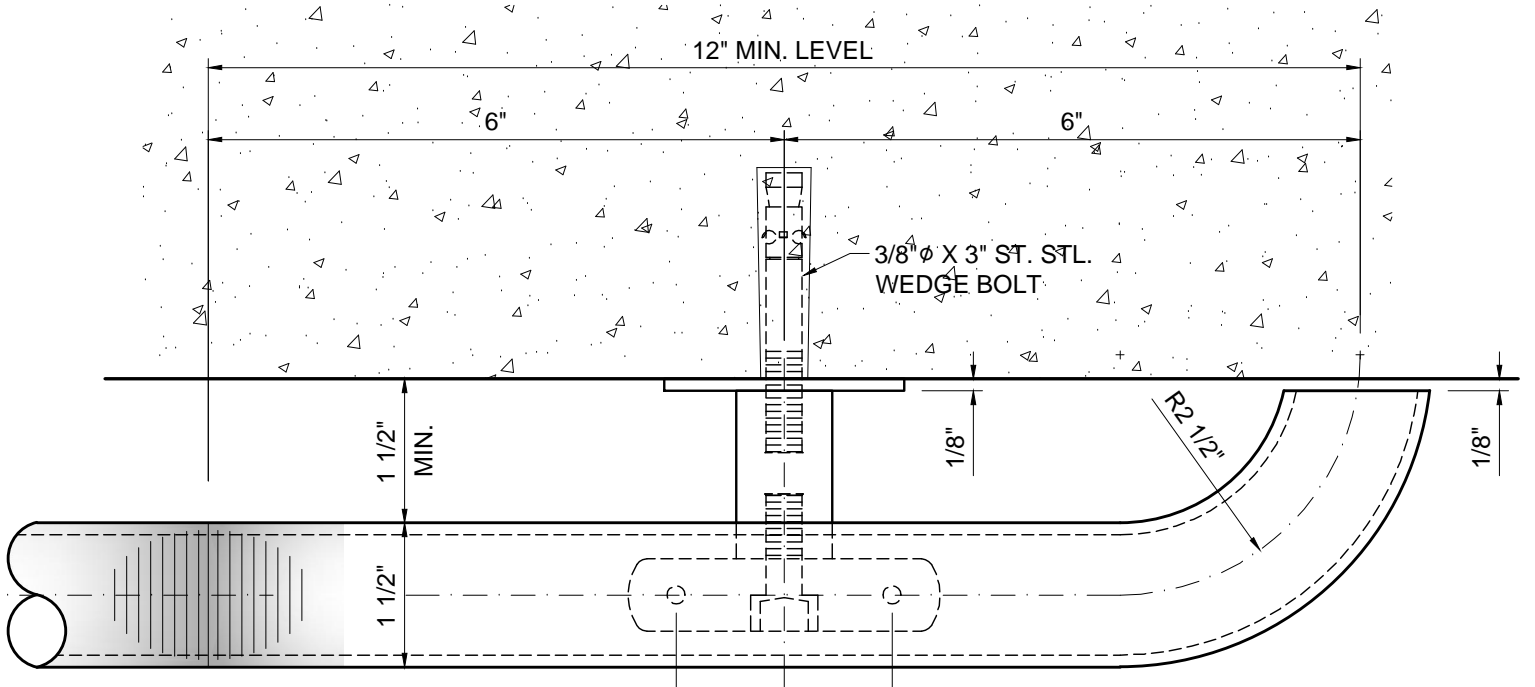

A TOP VIEW
 SCALE: HALF SIZE

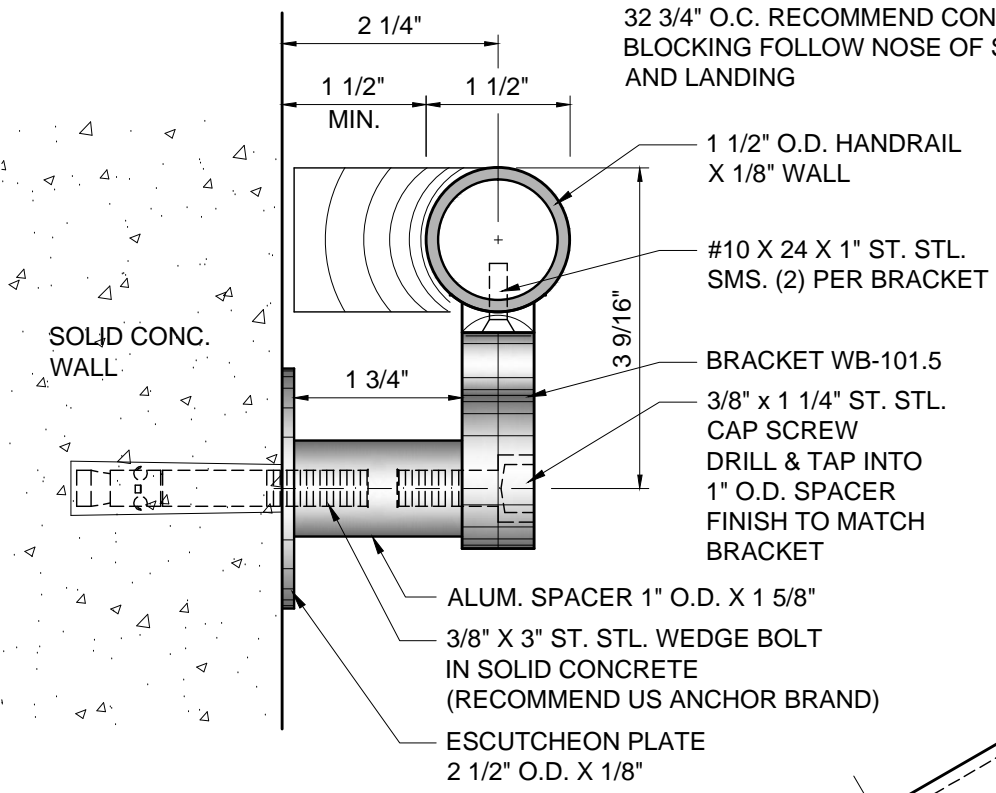

C BRACKET SECTION
 SCALE: HALF SIZE

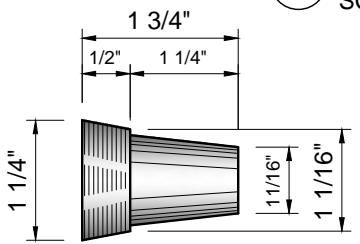

ALTERNATE SPACER
 PART NO. S-101C

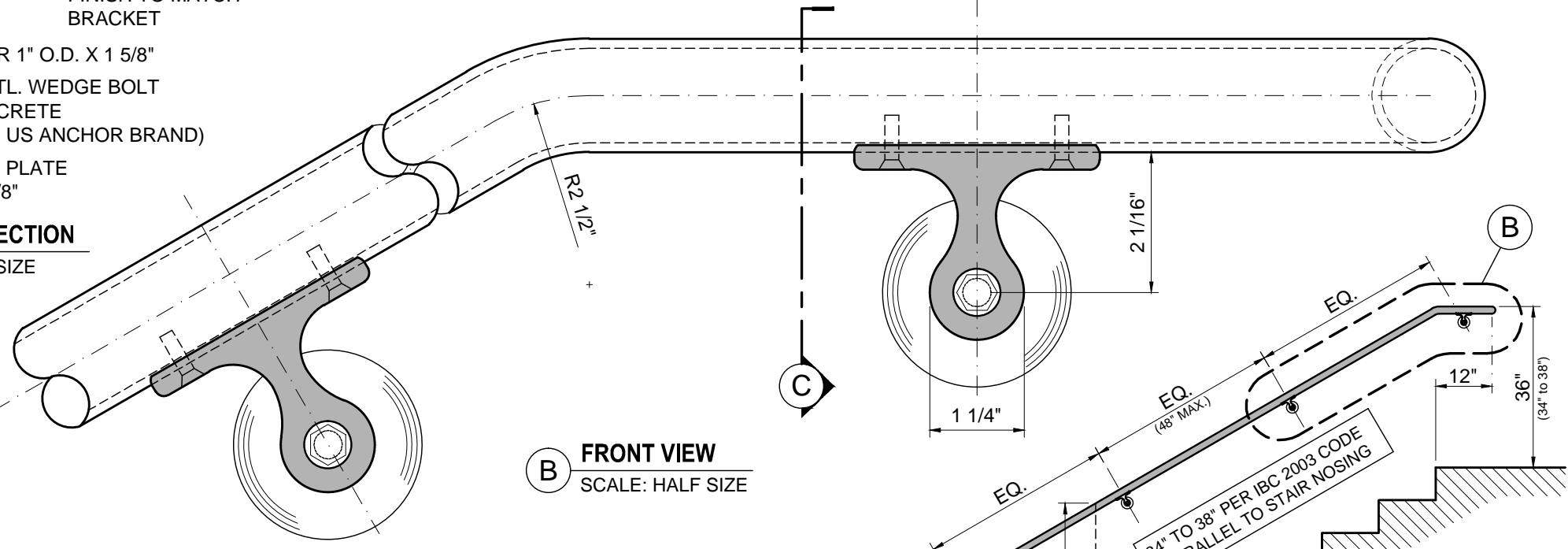

B FRONT VIEW
 SCALE: HALF SIZE

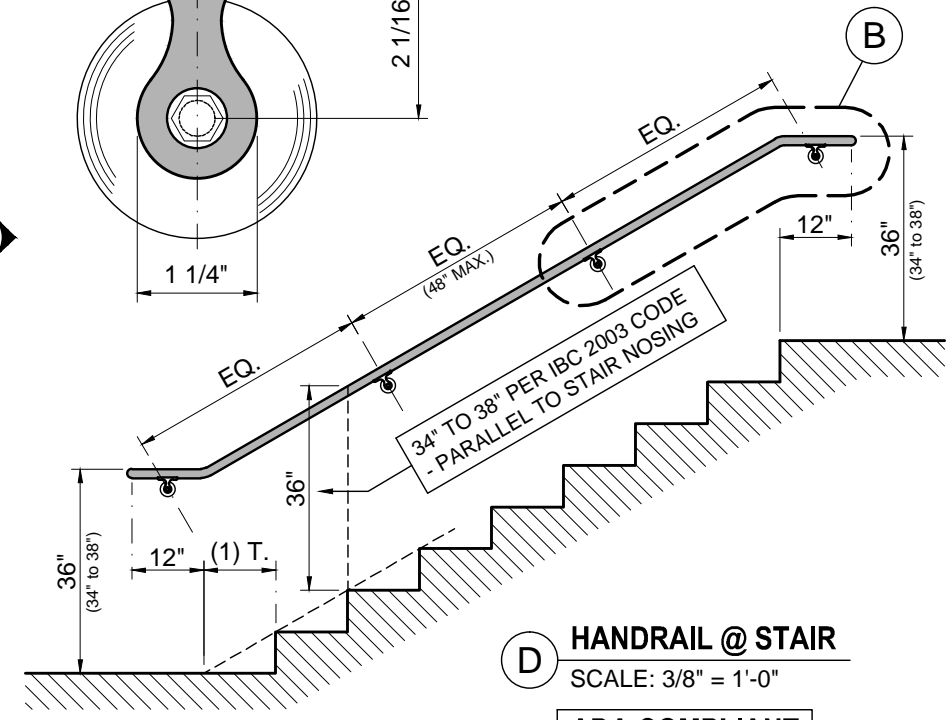

D HANDRAIL @ STAIR
 SCALE: 3/8" = 1'-0"

ADA COMPLIANT

ALL HANDRAIL AND BRACKET COMPONENTS ARE FURNISHED WITH
 CLEAR OR BRONZE ANODIZED FINISH - OR IN SOLID BRONZE
 (ALLOY 385) WITH #4 SATIN FINISH

WALL-MOUNT HANDRAIL & BRACKET WB 101.5